



## HA18 PX



### OPTIMAL PRODUCTIVITY

- > Continuous 360° turntable rotation
- > Fully proportional controls and simultaneous boom functions
- > Lifts to full height in 44 seconds

### OUTSTANDING ROUGH TERRAIN DRIVING FEATURES

- > 4 wheel steer and 4 wheel drive mean greater manoeuvrability
- > Hydraulic differential lock
- > 40 cm ground clearance

### 10.6 M OUTREACH PROVIDES A LARGE WORKING ENVELOPE

# HA18 PX

## ROUGH TERRAIN ARTICULATING BOOMS

### TECHNICAL DATA

#### HA18 PX

Working height	17.2 m
Platform height	15.2 m
Horizontal outreach	10.6 m
Up and over clearance	6.6 m
Lift capacity	230 kg (2 pers.)
<b>F</b> x <b>G</b> Platform size	1.8 x 0.8 m
<b>A</b> Length - stowed	7.6 m
Storage / transport length	5.9 m
<b>B</b> Width	2.3 m
<b>C</b> Height - stowed	2.3 m
Storage / transport height	2.6 m
Vertical jib rotation	140° (+ 70 / - 70)
Platform rotation	178° (+ 89 / - 89)
Turntable rotation	360° continuous
Tailswing	0 m
<b>D</b> Wheelbase	2 m
<b>E</b> Ground clearance	40 cm
Tilt	5°
Drive speed	0.8 - 5.5 km/h
Gradeability	50 %
Turning radius - outside	3.75 m
Tyres - foam-filled	385 / 65 - 22.5
Power source	Deutz, 31.2 kW (42.4 hp), Stage 3A
Hydraulic system capacity	100 l
Fuel tank capacity	75 l
Weight	8050 kg

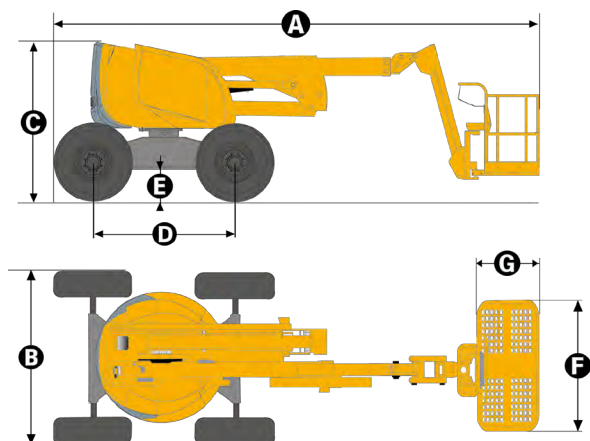

### STANDARD EQUIPMENT

- > 4 wheel drive and steer
- > Continuous 360° turntable
- > Safe to use in winds up to 60 km/h
- > Swing out engine tray for ease of maintenance
- > 75 l fuel tank, 1.50 m filling height
- > 5° tilt alarm
- > 12 V battery / electrical control system
- > Auxiliary power in the platform for emergency descent
- > Brake release
- > Hourmeter
- > Stewing block pin
- > Towing hooks / lifting eyes

### OPTIONS AND ACCESSORIES

- > Large basket 2.3 x 0.80 m (safe to use in winds up to 45 km/h - 28 mph)
- > Power to platform
- > Air line in platform
- > 4.1 kW on-board generator
- > Biodegradable hydraulic oil
- > Warm environment kit
- > Cold weather package
- > Travel alarm
- > Rotating beacon
- > Working light

