

# GTX16/18/20s

Electric Lift Trucks

Superelastic Tyres

1.600 kg 1.800 kg 2.000 kg

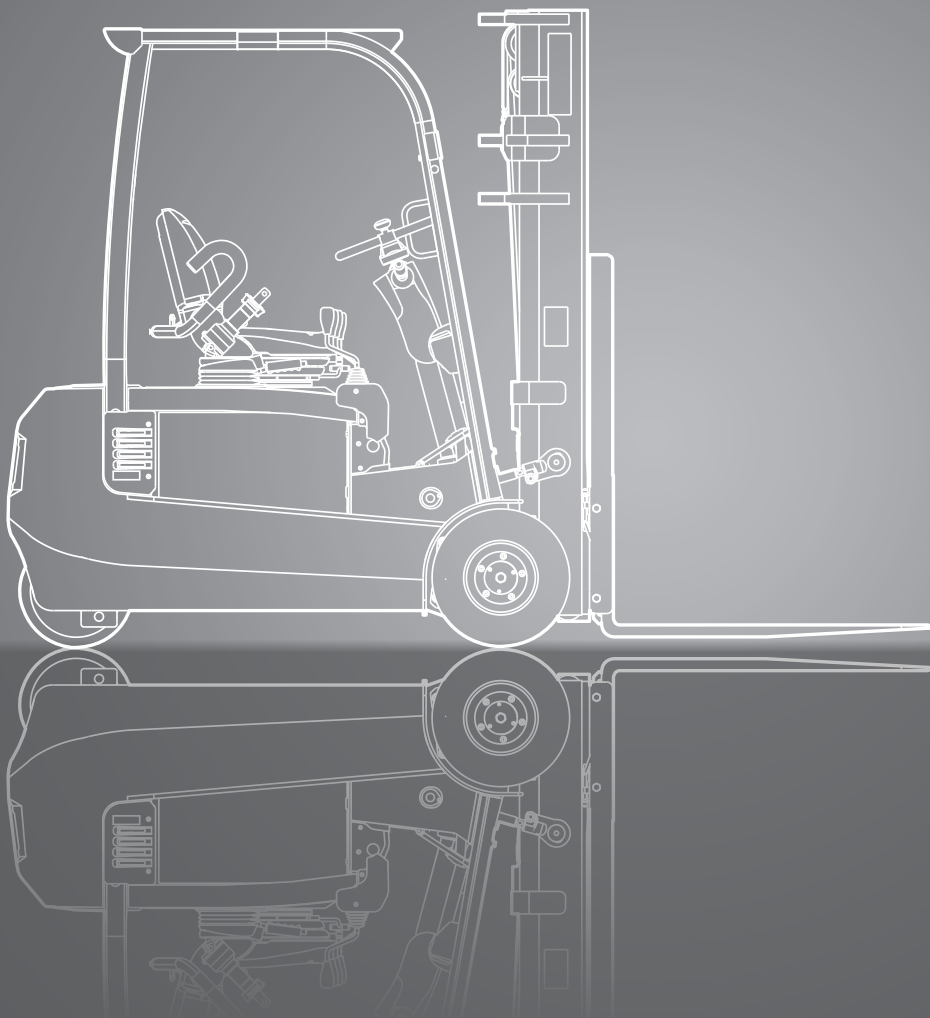

# DIMENSIONS

## GTX16/18/20s

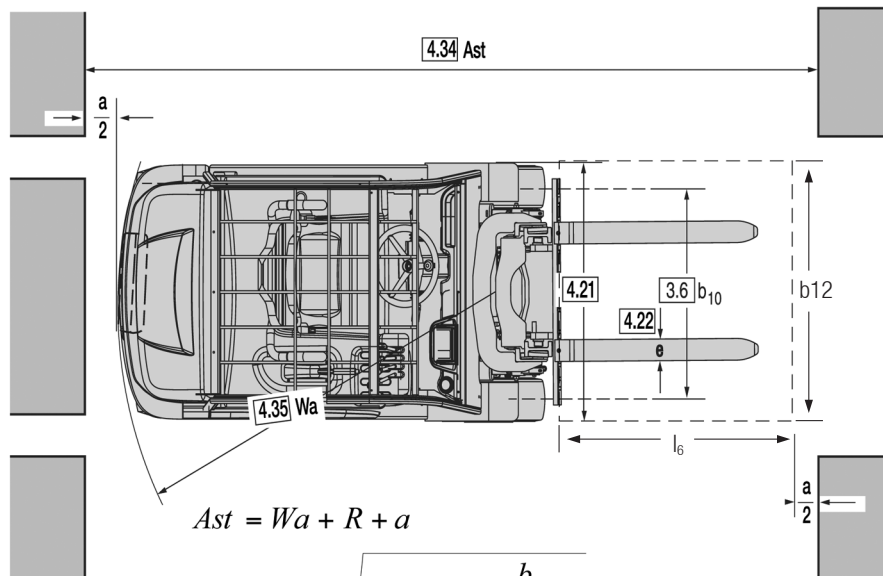
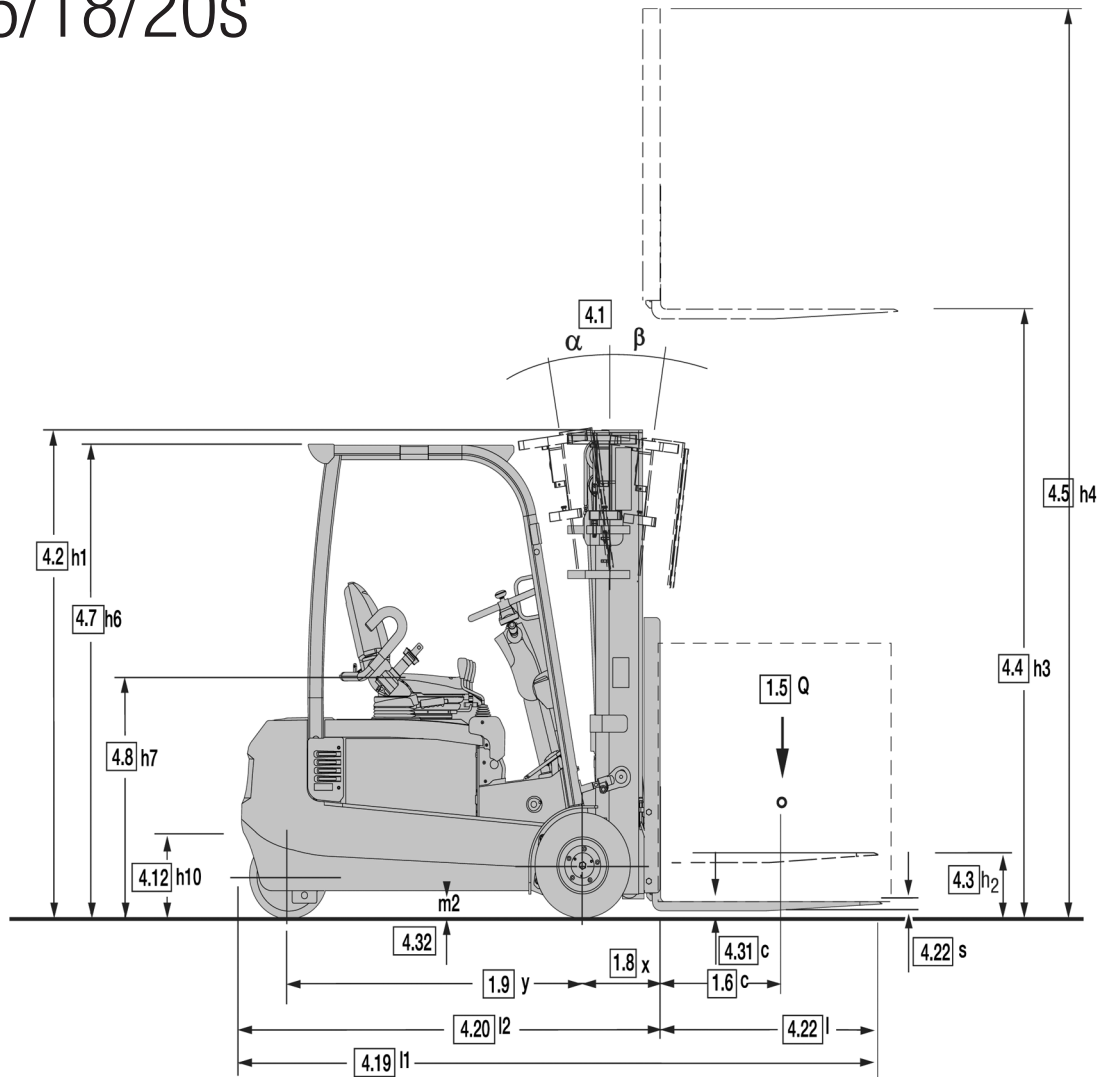

$$Ast = Wa + R + a$$

$$Ast = Wa + \sqrt{(l_6 + x)^2 + \left(\frac{b_{12}}{2}\right)^2} + a$$

$$a = 200 \text{ mm}$$

For corresponding data see Specification Chart.

# SPECIFICATIONS

## Product Specifications acc. to VDI 2198

1.1 Manufacturer (Abbreviation)		CLARK	CLARK	CLARK
Specifications	1.2 Manufacturer's designation	<b>GTX16</b>	<b>GTX18</b>	<b>GTX20s</b>
	1.3 Drive unit	Elec-48V	Elec-48V	Elec-48V
	1.4 Operator type stand on / driver seated	Rider-seated	Rider-seated	Rider-seated
	1.5 Load capacity / rated load Q (kg)	1600	1800	2000
	1.6 Load centre distance c (mm)	500	500	500
	1.8 Load centre distance, centre of drive axle to fork face x (mm)	356	356	361
	1.9 Wheelbase y (mm)	1312	1420	1420
Weight	2.1 Service weight kg	3051	3182	3375
	2.2 Axle loading, laden front / rear kg	4170/481	4444/539	4791/584
	2.3 Axle loading, unladen front / rear kg	1610/1441	1564/1618	1591/1784
Tyres, Chassis	3.1 Tyre type, SE = superelastic, C = cushion	SE	SE	SE
	3.2 Tyre size, front, superelastic	18x7-8	18x7-8	200/50-10
	3.3 Tyre size, rear, superelastic	15x4.5x8	15x4.5x8	15x4.5x8
	3.5 Wheels, number front/rear (x = drive wheels)	2x/2	2x/2	2x/2
	3.6 Tread, front SE (C) b10 (mm)	905	905	915
	3.7 Tread, rear b11 (mm)	194	194	194
	Dimensions	4.1 Tilt of upright/fork carriage, a / b deg	6/6	6/6
4.2 Height, upright lowered h1 (mm)		2060	2060	2060
4.3 Freelift h2 (mm)		132	132	132
4.4 Lift height *1 h3 (mm)		3085	3085	3085
4.5 Height, upright extended (with load backrest) h4 (mm)		4309	4309	4304
4.7 Height overheadguard (Cabin) h6 (mm)		2066 (2101)	2066 (2101)	2066 (2101)
4.8 Seat height h7 (mm)		1020	1020	1020
4.12 Coupling height h10 (mm)		360	360	360
4.19 Overall length l1 (mm)		2966	3074	3119
4.20 Length to face of forks l2 (mm)		1896	2004	2049
4.21 Width b1 (mm)		1059	1059	1122
4.22 Fork dimensions s*e*1 (mm)		40x100x1070	40x100x1070	40x100x1070
4.23 Fork carriage DIN 15173, A, B		II A	II A	II A
4.24 Fork carriage width b3 (mm)		940	940	940
4.31 Ground clearance minimum, laden m1 (mm)		85	85	85
4.32 Ground clearance centre of wheelbase m2 (mm)		100	100	100
4.34 Stacking aisle for pallets (l6 • b12) 1000 x 1200 across Ast (mm)		3223	3331	3375
4.34 Stacking aisle for pallets (l6 • b12) 800 x 1200 along Ast (mm)	3347	3455	3499	
4.35 Turning radius Wa (mm)	1540	1648	1688	
Performance	5.1 Travel speed laden/unladen km/h	15/16	15/16	15/16
	5.2 Lift speed laden/unladen m/s	0,40/0,50	0,37/0,50	0,35/0,50
	5.3 Lowering speed laden/unladen m/s	0,57/0,52	0,57/0,52	0,57/0,52
	5.6 Max. drawbar pull laden/unladen (S2 5 min) *2 N	7561/10523	7384/16426	7492/16103
	5.8 Max. gradeability laden/unladen (S2 5 min) *2 %	27,3/38,5	25,7/35,7	24,7/32
	5.10 Service brake	Wet disc brake	Wet disc brake	Wet disc brake
Drive line	6.1 Drive motor rating (S2 60 min) kW	2x4.4	2x4.4	2x4.4
	6.2 Lift motor rating (S3 15%) kW	15,2	15,2	15,2
	6.3 Battery acc. to DIN43531/35/36	DIN43531A	DIN43531A	DIN43531A
	6.4 Battery voltage, nominal capacity K5 V/Ah	48/460(500)	48/575(625)	48/575(625)
	6.5 Battery weight (min) kg	708	856	856
Miscel.	8.1 Type of control	AC / Inverter	AC / Inverter	AC / Inverter
	8.2 Operating pressure for attachments bar	max. 140	max.140	max. 140
	8.3 Oil volume for attachments dB (A)	68	68	68

\*1 Further lift heights see upright table

\*2 At friction coefficient  $\mu=0.8$  with 1.6 km/h

All values shown are for standard lift truck with standard equipment. If the truck is supplied with options, values may change. All values given may vary +5% and -10% due to the motor and system tolerances and represent nominal values obtained under typical operating conditions. Specifications for Non-emission limited truck.

# PRODUCT DESCRIPTION

Two powerful AC motors driving the front wheels, a very sturdy design without unnecessary plastic components and an extremely short wheelbase, distinguish the GTX series from CLARK. Suitable for most applications thanks to a solid „Built to Last ©“ construction and well thought-out driver's compartment.

## Operator's Compartment

A large low positioned step, together with a grab handle on the driver's guard column allows easy access to the ergonomically designed operator's compartment. A full width rubber floor covering in the footwell ensures a firm footing in all conditions. The tilting steering column and an easily adjustable comfort seat, gives maximum legroom enabling optimal adjustment to suit any driver.

The operator's foot pedals are arranged in the automotive fashion to avoid any confusion. The fully directional operating levers move smoothly giving precise control and are located at a perfect height to enable easy handling and a firm grip. Essential operating data is displayed in real-time on the clear TFT LCD colour display. Three individually programmable operating modes (Economy-Normal-Power) as well as an additional crawl function allows you to optimally adapt the vehicle to the relevant work situation. Easily accessible stowage compartments as well as quick access to the hand brake and emergency stop switch complete this impressive operator's compartment.

## Motor, drive and control

Two powerful 4.4 kW AC motors driving the front wheels and 48 Volt three-phase current technology ensure excellent acceleration and high performance. The maintenance free AC motors ensure running costs are kept to a minimum.

The temperatures of the motors and controller are constantly monitored with the power being automatically adjusted to prevent design limits being exceeded.

The ZAPI DUAL AC control is equipped with modern MOSFET and CAN bus technology and is located safely, high in the counterweight, where it is protected, yet easily accessible. The motor and controller temperature monitoring devices serves to protect your investment.

## Brake system

Three independent brake systems (electrical, foot and parking brake) ensure increase efficiency through improved utilisation of the battery capacity and high safety. Fully enclosed oil-immersed multiple-disc, foot and parking brake provide constant brake performance in all conditions.

The regenerative electrical brakes return energy to the battery during each braking action. This process saves energy costs, reduces brake wear and extends the driving time per battery charge. If the driving direction is changed by operation of the direction lever, the electronics ensure gentle braking and progressive acceleration in the new direction of travel. The fully enclosed service brakes are protected against dust, damp and aggressive particles. Use under difficult environmental conditions is therefore possible without any problems. The standard ramp start feature enables controlled operation of the truck on gradients and precise handling on loading platforms.

## Steering system

The standard dual-wheel steer axle increases the maneuverability and stability of the truck. Depending on the angle of the steer wheels, the speed and direction of rotation of the front wheels is controlled in such a way that significant wear of the tyres is avoided. When cornering, the traction speed is automatically reduced proportional to the degree of turn.

## Hydraulic system

The independent, AC powered hydraulic pump only pumps the required oil volume for the relevant task, ensuring optimum energy efficiency and longer battery shift life.

The internal gear hydraulic pump is distinguished by especially low pump noise combined with high efficiency. This saves energy and reduces the heat load on the hydraulics. The steel hydraulic tank ensures good heat dissipation for the hydraulic oil ensuring long service life for the hydraulic components. The full-flow return line filtration filters the oil to the tank at each reverse flow. Large particles are filtered directly via a suction filter, thereby preventing them from entering the oil circuit. This ensures a long service life for all hydraulic components.

## Upright

The clear-view uprights are available in Standard, Hilo and Triplex versions. The interlocking profiles provide high strength and improved safety, even at high levels. Enclosed canted rollers minimize deflection and can easily be adjusted without major disassembly. Tilt cylinders are mounted in spherical bushings, eliminating hydraulic seal strain, thereby increasing the service life of the complete cylinder. An integral tilt-lock valve prevents excessive tilt speeds and unintentional operation of the upright. The upset forged forks ensure long service life and are hook mounted and pin lockable to ensure accurate for positioning.

A hydraulic cushioning valve reduces upright shocks and allows smooth lifting and lowering at all times, ensuring a long service life and less product damage. The sturdy 6-roller fork carriage features enclosed canted rollers together with adjustable side thrust rollers, preventing carriage jamming when handling offset loads.

## Further standard equipment

Working headlights, acoustic reversing alarm, combination rear lights incorporating brake and reverse light, paintwork in a bright safety colour „CLARK Green“, driver's compartment and upright in matt black, wheel rims in white finish.

## Optional equipment

Pneumatic or non-marking tyres, side battery change, attachments, cabs, mini- or multifunction levers and much more

## Safety

The GTX series is CE certified and corresponds to all European safety standards for counterbalanced forklift trucks.

Talk to your CLARK dealer to find the optimum equipment for you.

# GENERAL DATA

## Truck Capacities Capacity at different load centres

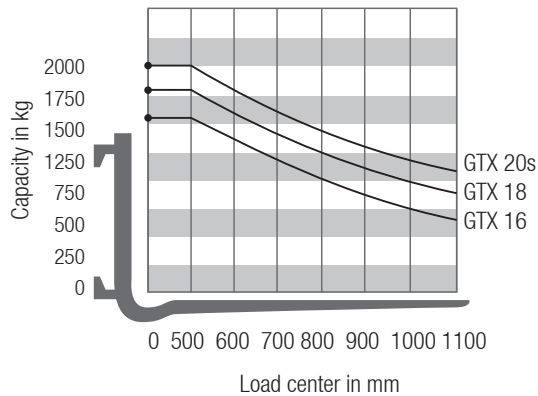

### Note:

The listed capacities are valid only for the standard upright in vertical position with standard fork carriage and standard forks, up to max. lifting height of 3085 mm. The centre of gravity of the load may be displaced by max. 100 mm against the longitudinal centre plane of the truck. Load centre is determined from top and front face of the forks. The values are based on a 1000 mm cube load configuration with the centre of gravity at the true centre of the cube with upright tilted forward lower capacity values are valid. Attachments, longer forks, exceptional load dimensions and higher lifting heights can reduce the capacity.

Please talk to your CLARK dealer if you require further information.

## Upright table GTX 16/18/20s

Mast type	Maximum Fork Height (h3)	Mast Lowered (h1)	Mast Extended (h4)		Free lift (h2)	
			with load backrest	without load backrest	with load backrest	without load backrest
	mm	mm	mm	mm	mm	mm
Standard	2545	1792	3771	3169	132	132
	2795	1917	4021	3419		
	3085	2060	4311	3709		
	3285	2162	4511	3909		
	3639	2339	4865	4263		
	4069	2612	5295	4693		
	4365	2812	5591	4989		
	4653	3007	5879	5277		
Triple	3970	1835	5194	4594	611	1211
	4345	1960	5569	4969	736	1336
	4780	2105	6004	5404	881	1481
	5185	2255	6409	5809	1031	1631
	5565	2415	6789	6189	1191	1791
	5740	2480	6964	6364	1256	1856
	6015	2605	7239	6639	1381	1981
	6470	2795	7694	7094	1571	2171
7075	3050	8299	7699	1826	2426	
HI-LO	2925	1960	4149	3549	736	1336
	3215	2105	4439	3839	881	1481
	3515	2255	4739	4139	1031	1631
	3695	2345	4919	4319	1121	1721
	3810	2415	5034	4434	1191	1791

Performance may vary +5% and -10% due to motor and system efficiency tolerance. The performance shown represents nominal values which may be obtained under typical operating conditions of a machine. CLARK products and specifications are subject to change without notice.

**CLARK Europe GmbH**  
Dr.- Alfred-Herrhausen-Allee 33  
D - 47228 Duisburg / Germany  
Tel.+49 (0)2065 499 13-0  
Fax+49 (0)2065 499 13-290  
email:info-europe@clarkmheu.com  
www.clarkmheu.com

Dealer: