



TECHNICAL DATA

GENERAL		C 501 H x4
Load capacity to 500 mm	kg	-
Load capacity to 600 mm	kg	5000
Unladen weight *	kg	7710
Transmission	-	Hydrostatic
MAST		
Fork carriage	-	FEM 4
Carriage width	mm	1660
ENGINE		
Make	-	DEUTZ
Model	-	TD 3.6
Power	kW	55,4
Operating speed	rpm	2000
Torque	N-m@rpm	330@1600
No. cylinders	-	4
Emissions	-	Stage V
Ambient noise	dB(A)	104
DRIVING		
Max. speed	km/h	20
Gradability	%	35
Traction	-	4x4 FullGrip®
Front tyres	-	18-19.5
Rear tyres	-	12-16.5
HYDRAULIC SYSTEM		
Hydraulic circuit	-	Two gears pump
Flow rate	l/min	59
Working pressure	bar	235
TANK CAPACITY		
Fuel	l	117
Hydraulic	l	114
BRAKES		
Service	-	Hydraulic, multi-disc and sealed
Parking	-	Negativ, multi-disc and sealed

* It may change due to optional equipment

DIMENSIONS

TYPE OF MAST	Maximum lift (mm)	H Retracted mast height (mm)	Extended mast height (mm)	Free lift (mm)	Load at maximum height (kg) All-terrain use
Duplex mast (Std.)	3700	2750	4585	100	-
Triplex mast	4250	2350	5260	1393	-
Triplex mast	5450	2750	6460	1793	1880

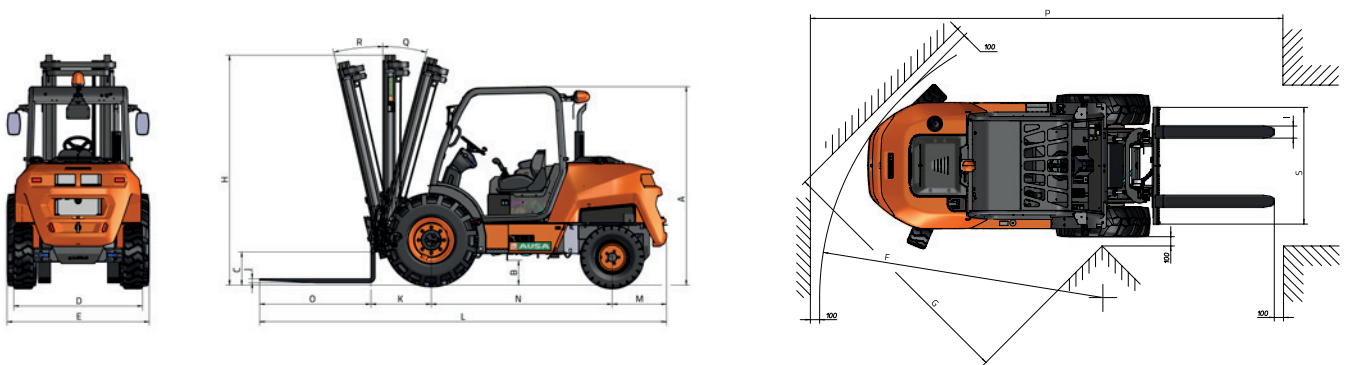

DIMENSIONS (mm)

C 501 H x4

A	2350
B	280
C	290
D	1760
E	2010
E*	2010
F	4410
G	3210
I	120
J	50
K	720
L	4610
M	640
N	2050
O	1200
P	6430
S	1660
S**	1660
DIMENSIONS (°)	
Q	10
R	10

* Measured with high-lift mast installed **Measured for wide axle carriage



www.ausa.com

Products are subject to modifications without prior notice. Images throughout the spec sheet may refer to non-standard machines or non-available configurations depending on models.

AUSA's logo and corporate identity are property of the Company, they cannot be used without authorization.